

Incorrect or out of phase engine timing can result in damage to the valves. The Tool Connection cannot be held responsible for any damage caused by using these tools in anyway.

Safety Precautions – Please read

- Disconnect the battery earth leads (check radio code is available)
- Remove spark or glow plugs to make the engine turn easier
- Do not use cleaning fluids on belts, sprockets or rollers
- Always make a note of the route of the auxiliary drive belt before removal
- Turn the engine in the normal direction (clockwise unless stated otherwise)
- Do not turn the camshaft, crankshaft or diesel injection pump once the timing chain has been removed (unless specifically stated)
- Do not use the timing chain to lock the engine when slackening or tightening crankshaft pulley bolts
- Do not turn the crankshaft or camshaft when the timing belt/chain has been removed
- Mark the direction of the chain before removing
- It is always recommended to turn the engine slowly, by hand and to re-check the camshaft and crankshaft timing positions.
- Crankshafts and Camshafts may only be turned with the chain drive mechanism fully installed.
- Do not turn crankshaft via camshaft or other gears
- Check the diesel injection pump timing after replacing the chain
- Observe all tightening torques
- Always refer to the vehicle manufacturer's service manual or a suitable proprietary instruction book
- Incorrect or out of phase engine timing can result in damage to the valves
- It is always recommended to turn the engine slowly, by hand, and to re-check the camshaft and crankshaft timing positions



www.lasertools.co.uk

Guarantee

Distributed by The Tool Connection Ltd
Kington Road, Southam, Warwickshire CV47 0DR
T +44 (0) 1926 815000 F +44 (0) 1926 815888
info@toolconnection.co.uk www.toolconnection.co.uk

If this product fails through faulty materials or workmanship, contact our service department direct on: **+44 (0) 1926 818186**. Normal wear and tear are excluded as are consumable items and abuse.

www.lasertools.co.uk

LASER®

Part No. 3785

Master Engine Timing Tools

Opel | Vauxhall | Isuzu



www.lasertools.co.uk

Plan Layout

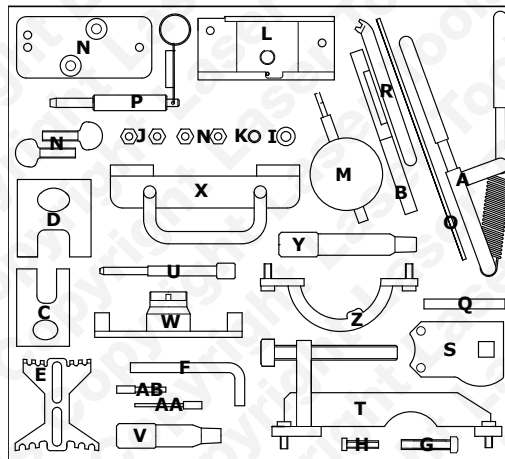

Ref	Code	Oem Code	Description
A	C205	KM 8070	Tensioner Adjuster
B	C207	KM 852	Camshaft Setting Bracket
C	C211	KM 853	Camshaft Locking Tool
D	C212	KM 517B	Camshaft Locking Tool
E	C213	KM 6011	Flywheel Locking Tool
F	C053	Locking Screw	Flywheel Locking Pin Ø 9,5 mm
G	C064	Locking Screw	M8 x 40mm
H	C067	KM 661-1	M8 x 35mm
I - L	C073	KM 571-B	Camshaft Locking Tool
M	C195	KM 661-2	Dial Test Indicator 51 Dia. x 10 x 0,01 mm
N	C163	KM 851	Camshaft Position Locking Tool
O	C165	KM 951	Flywheel TDC Indicator
P	C166	KM 652	Flywheel Locking Pin
Q	C167	KM 911	Flywheel Locking Tool
R	C168	KM 933	Flywheel Locking Tool
S	C169	KM 933	Timing Adjustment Wrench
T	C170	KM 927	Bracket for Timing Adjustment Wrench
U	C171	KM 929	Injection Pump Setting Pin
V	C172	KM 932	Flywheel Locking Pin
W	C173	KM 953	Camshaft Locking Tool
X	C174	KM 952	Camshaft Locking Tool
Y	C175	KM 954	Flywheel Locking Pin
Z	C176	KM 955	Camshaft Position (CMP) Sensor Disc Setting Tool
AA	C177	KM 955	Tensioner Retaining Pin 2,5 mm. Dia.
AB	C178	KM 955	Tensioner Retaining Pin 4,0 mm. Dia.

Applications

The application list for this product has been compiled cross referencing the OEM Tool Code with the Component Code.

In most cases the tools are specific to this type of engine and are necessary for Cam belt or chain maintenance.

If the engine has been identified as an interference engine valve to piston damage will occur if the engine is run with a broken Cam belt.

A compression check of all cylinders should be performed before removing the cylinder head.

Always consult a suitable work shop manual before attempting to change the Cam belt or Chain.

Autodata

Our applications data is supplied by Autodata and we are able to supply this data to you in a PDF format.

If this is a specific kit for a group of engine codes the application list has been supplied showing the main vehicles this kit is designed for and does not list every model each pin fits.

If this is a master kit then all vehicles are included.

The data is the copyright of Tool Connection and should not be reproduced.

If the application data is extensive we have included a CD with the application list in .pdf format.

Languages

We have also included where possible translations for the instructions in the following languages:

- French
- Spanish
- German
- Portuguese
- Italian
- Dutch

The use of these engine timing tools is purely down to the user's discretion and Tool Connection cannot be held responsible for any damage caused what so ever.

ALWAYS USE A REPUTABLE WORKSHOP MANUAL

Instruction

Adjusting Timing (N)

Ensure that the timing belt tension is correct. All timing marks must be aligned and the engine at (TDC) Top Dead Centre.

- Using a 22 mm. open-ended spanner on the camshaft hexagon to stop it from turning, loosen the fastening bolt of the camshaft sprocket. It is important that the position of the crankshaft and camshaft remain unchanged.
- The Camshaft should now be turned using the spanner in the normal direction of rotation until the dial test indicator reads approximately 0,80mm.
- Using the spanner, turn the camshaft back in the opposite direction of normal rotation until the Dial Test Indicator reads 0.60-0.64mm. It is important that the camshaft does not move from this position. Fit the Camshaft Locking Tool (N) to any of the remaining three cylinder positions, and adjust the thumbscrews down until they make contact with the cam lobes. Fit a new bolt to retain the camshaft sprocket and tighten to the specified torque. Remove both timing tools, but do not change the Dial Test Indicator setting.
- Rotate the crankshaft two full revolutions to the correct timing marks. Re-install the camshaft measuring tool, ensuring that the Dial Test Indicator is in the left stop position, with the (DTI) resting on the cam lobe. Check that the correct nominal measurement reading is shown as 0.55 +/- 0.03mm.

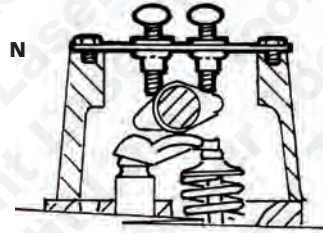

Flywheel TDC Setting Tool - 17DTL engine (-97) (O)

When removing/installing timing belt and establishing or checking correct timing position, the Flywheel Setting Tool is used to determine the flywheel/crankshaft TDC position. It is attached to the flywheel housing and provides the 'pointer' position on which to align the TDC mark.

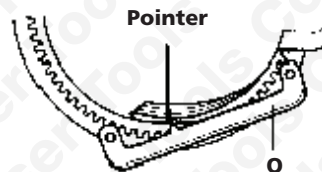

Flywheel/Crankshaft Locking Tools (P)

These are designed to pin-point and lock the engine at Top Dead Centre (TDC) by alignment of a datum hole in the flywheel/ engine casing and the flywheel. Place the correct Pin in the access hole and rotate the engine by hand until the locking pin engages with the flywheel timing hole, the engine is now locked in the correct timing position.



Instruction

Twin-Cam Locking Tools (C/D)

These tools enable the camshafts to be locked in relationship to each other because the pressure of the compressed valve springs can cause the position to change after the timing belt has been removed. Changing the timing belt is made easier by locking the camshafts in position and reduces the risk of damage. Damage will occur to the valves if they make contact with the piston after the correct timing position of the camshafts is lost.

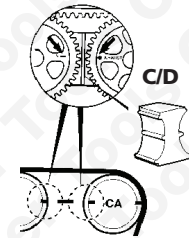

Flywheel Locking Tools (E, Q & R)

These tools are designed especially to enable the flywheel to be held static whilst releasing and re-tightening the pulley fastener, during timing belt replacement and engine timing activity. It is recommended that Crankshaft Timing Pins are not used for this purpose.

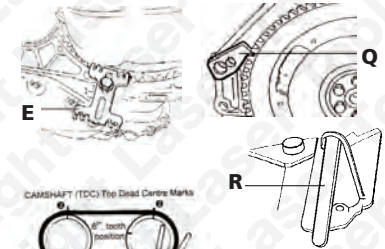

Tensioner Adjuster (A)

Check timing marks and make the following adjustments when the engine is at room temperature or cold. Attach Timing Belt Tensioner (A) as shown by outline and loosen the fastening bolt of toothed belt tension roller.

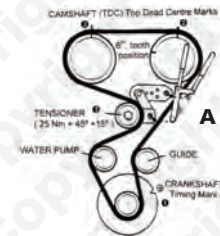

Engine Timing (W, U, V & S/T)

The correct engine timing position is achieved when the first cylinder is at TDC and each of the timing tools can be correctly fitted.

The camshaft is positioned horizontally with the location hole at the top. Use the camshaft setting tool (W) to align the camshaft.

The Injection Pump Setting Pin (U) aligns to a timing mark on the sprocket and is fitted through a recess in the injection pump flange and into the retaining hole.

The crankshaft locking pin (V) is used to set the crankshaft at TDC position. This tool is fitted through the crankshaft pulse pick-up opening in the engine block and locates into a slot in the crankshaft.

Fuel Pump Sprocket Timing Tool (S/T) enables the correct timing position through action to the simplex chain and camshaft sprocket. First attach the special wrench vertically to the sprocket, then attach the bracket assembly to the cylinder head. Using a 1/2" D. wrench to apply light pressure to turn the camshaft in an anti-clockwise (contra-engine rotation). The screw is turned to contact the special wrench and retain this position.

At this stage the Pump Locking Pin (U) should be free to be removed and re-fitted. If this pin is tight, adjust the screw until the pin is easy to move. The camshaft sprocket bolt can now be tightened and refit the simplex chain tensioner.

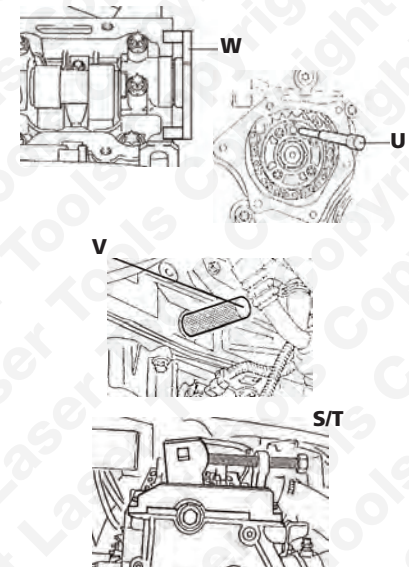

Instruction

Camshaft Setting Plate (X)

Used to correctly position both camshafts, and fits into the slots of each camshaft to align horizontally in relation to the top surface of the cylinder head.

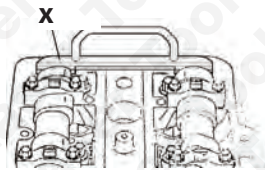

The crankshaft locking pin (Y)

Positions the crankshaft at TDC as it is inserted through the engine block and locates into a slot located on the first crank web of the crankshaft.

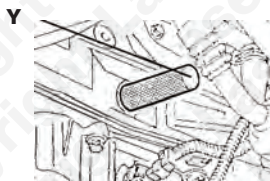

The Timing Disc Position Gauge (Z)

Connected to the inlet camshaft sprocket to achieve the correct timing position of the camshaft and the sensor disc.

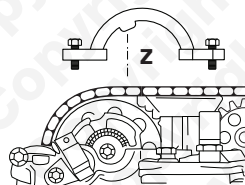

Tensioner retaining pins (AA/AB)

Used to retain the hydraulic activated tensioner rail which must be moved from contact with the simplex chain during the work of belt replacement.

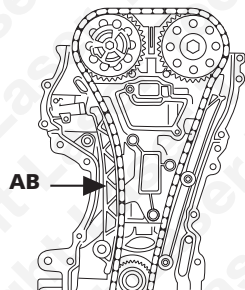
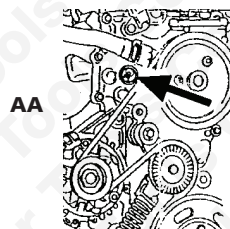

Instruction

Camshaft Setting Tool (M & I | J | K | L)

Camshaft Setting Tools (I-L) are used with Camshaft Locking Tool (M)

The Mounting Bracket Assy. (L) is used with the Dial Test Indicator using the Adapter Assembly (I) and replacing the Standard Tip on the Dial Test Indicator with Special Tip (K)

Ensure all timing marks align at crankshaft by using (L or M), and at the injection pump.

Carry out the timing belt tensioning procedure as per the manufacturer's instructions. The Belt tension must be correct.

Turn crankshaft in the normal engine direction of rotation to 90° before TDC (No1 cylinder).

Insert and fix Dial Test Indicator into Setting Plate. The DTI shaft must be held securely in the Adapter.

Initially retain the DTI shaft by lightly pinching with the Nut.

1. Fix the Mounting Bracket Assy (I) into the camshaft housing holes, by using the 2 x M6 x 10 mm. Setscrews, at 1st cylinder inlet valve (over 2nd cam lobe from front).
2. Push Plate to the right to rest against the right stop position. The DTI foot should rest on the base circle of the cam.
3. Release the Nut and pre-load the indicator to not more than 0.50 mm. and secure the (DTI) firmly in the Adaptor.
4. Zero the DTI bezel (datum point)
5. Push the Block to the left to rest against the left stop position so that the indicator rests over the cam lobe.

NOTE: The dial test indicator will now read below the datum point.

6. Turn crankshaft in the normal engine direction to TDC ensuring all timing marks align. The cam lobe will rise and the DTI will return to the zero datum point and continue to the correct nominal value 0.55 +/- 0.03mm. If the nominal value is not obtained, the cam timing must be adjusted.

